



How to wire your own ethernet cables and connectors.

What You Need:

Required:

- Cable - bulk Category 5, 5e, 6 or 7 cable
- Wire Cutters - to cut and strip the cable if necessary
- **For Patch Cables:**
- RJ45 Plugs
- RJ45 Crimper
- **For Fixed Wiring:**
- RJ45 Jacks
- 110 Punch Down Tool

Recommended:

- Wire Stripper
- Cable Tester

About the Cable:

You can find bulk supplies of the cable at many computer stores or most electrical or home centers. You want UTP (Unshielded Twisted Pair) Category 5 cable for basic 10/100 functionality. You want CAT 5e for gigabit (1000BaseT) operation and CAT 6 or 7 gives you a measure of future proofing. Bulk cable comes in many types, there are 2 basic categories, solid and braided cable. Braided cable tends to work better in patch applications for desktop use. It is more flexible and resilient than solid cable and easier to work with, but really meant for shorter lengths. Solid cable is meant for longer runs in a fixed position. Plenum rated cable must be used whenever the cable travels through an air circulation space. For example, above a false ceiling or below a raised floor. It may be difficult or impossible to tell from the package what type of cable it is, so peel out an end and investigate.

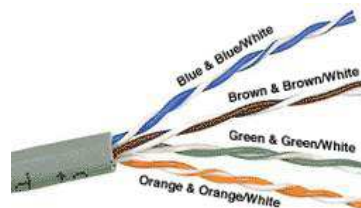

Here is what the internals of the cable look like:

Internal Cable Structure and Color Coding

Inside the cable, there are 8 color coded wires. These wires are twisted into 4 pairs of wires, each pair has a common color theme. One wire in the pair being a solid or primarily solid colored wire and the other being a primarily white wire with a colored stripe (Sometimes cables won't have any color on the striped wire, the only way to tell which is which is to check which wire it is twisted around). Examples of the naming schemes used are: Orange (alternatively Orange/White) for the solid colored wire and White/Orange for the striped cable. The twists are extremely important. They are there to counteract noise and interference. It is important to wire according to a standard to get proper performance from the cable. The TIA/EIA-568-A specifies two wiring standards for an 8-position modular connector such as RJ45. The two wiring standards, T568A and T568B vary only in the arrangement of the colored pairs. Tom writes to say "...sources suggest using T568A cabling since T568B is the AT&T standard, but the US Government specifies T568A since it matches USOC cabling for pairs 1 & 2, which allows it to work for 1/2 line phones...". Your choice might be determined by the need to match existing wiring, jacks or personal preference, but you should maintain consistency. I've shown both below for straight through cabling and just T568B for cross over cabling.

About RJ45 Plugs and Jacks:

The RJ45 plug is an 8-position modular connector that looks like a large phone plug. There are a couple variations available. The primary variation you need to pay attention to is whether the connector is intended for braided or solid wire. For braided/stranded wires, the connector has sharp pointed contacts that actually pierce the wire. For solid wires, the connector has fingers which cut through the insulation and make contact with the wire by grasping it from both sides. The connector is the weak point in an ethernet cable, choosing the wrong one will often cause grief later. If you just walk into a computer store, it's nearly impossible to tell what type of plug it is. You may be able to determine what type it is by crimping one without a cable.

RJ45 jacks come in a variety styles intended for several different mounting options. The choice is one of requirements and preference. RJ45 jacks are designed to work only with solid cable. Most jacks come labeled with color codes for either T568A, T568B or both. Make sure you end up with the correct one.



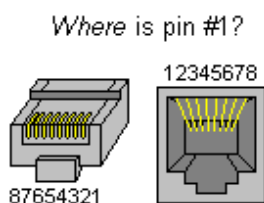





Here is a diagram and pin out:







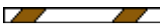

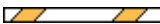

RJ45 Plug and Jack Pin Out

Ethernet Cable Pin Outs:

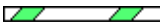
There are two basic cable pin outs. A straight through cable, which is used to connect to a hub or switch, and a cross over cable used to operate in a peer-to-peer fashion without a hub/switch. Generally all fixed wiring should be run as straight through. Some ethernet interfaces can cross and un-cross a cable automatically as needed, a handy feature.

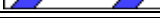







RJ45 Pin #	Wire Color (T568A)	Wire Diagram (T568A)	10Base-T Signal 100Base-TX Signal	1000Base-T Signal
1	White/Green		Transmit+	BI_DA+
2	Green		Transmit-	BI_DA-
3	White/Orange		Receive+	BI_DB+
4	Blue		Unused	BI_DC+
5	White/Blue		Unused	BI_DC-
6	Orange		Receive-	BI_DB-
7	White/Brown		Unused	BI_DD+
8	Brown		Unused	BI_DD-

Straight-Through Cable Pin Out for T568A

RJ45 Pin #	Wire Color (T568B)	Wire Diagram (T568B)	10Base-T Signal 100Base-TX Signal	1000Base-T Signal
1	White/Orange		Transmit+	BI_DA+
2	Orange		Transmit-	BI_DA-
3	White/Green		Receive+	BI_DB+
4	Blue		Unused	BI_DC+
5	White/Blue		Unused	BI_DC-
6	Green		Receive-	BI_DB-
7	White/Brown		Unused	BI_DD+
8	Brown		Unused	BI_DD-

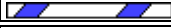
Straight-Through Cable Pin Out for T568B

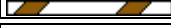
Cross Over Cable (T568B):

RJ45 Pin # (END 1)	Wire Color	Diagram End #1	RJ45 Pin # (END 2)	Wire Color	Diagram End #2
1	White/Orange		1	White/Green	
2	Orange		2	Green	
3	White/Green		3	White/Orange	
4	Blue		4	White/Brown	
5	White/Blue		5	Brown	
6	Green		6	Orange	
7	White/Brown		7	Blue	
8	Brown		8	White/Blue	

Cross Over Cable Pin Outs

+Note: The cross over cable layout is suitable for 1000Base-T operation, all 4 pairs are crossed.

How to wire Ethernet Patch Cables:

1. Strip off about 2 inches of the cable sheath.
2. Untwist the pairs - don't untwist them beyond what you have exposed, the more untwisted cable you have the worse the problems you can run into.
3. Align the colored wires according to the diagrams above.
4. Trim all the wires to the same length, about 1/2" to 3/4" left exposed from the sheath.
5. Insert the wires into the RJ45 plug - make sure each wire is fully inserted to the front of the RJ45 plug and in the correct order. The sheath of the cable should extend into the RJ45 plug by about 1/2" and will be held in place by the crimp.
6. Crimp the RJ45 plug with the crimper tool.
7. Verify the wires ended up the right order and that the wires extend to the front of the RJ45 plug and make good contact with the metal contacts in the RJ45 plug
8. Cut the cable to length - make sure it is more than long enough for your needs.
9. Repeat the above steps for the second RJ45 plug.

How to wire fixed Ethernet Cables:









1. Run the full length of cable in place, from endpoint to endpoint, making sure to leave excess.
2. At one end, cut the wire to length leaving enough length to work, but not too much excess.
3. Strip off about 2 inches of the cable sheath.
4. Align each of the colored wires according to the layout of the jack.
5. Use the punch down tool to insert each wire into the jack.
6. Repeat the above steps for the second RJ45 jack.

If a cable tester is available, use it to verify the proper connectivity of the cable. That should be it, if your cable doesn't turn out, look closely at each end and see if you can find the problem. Often a wire ended up in the wrong place or one of the wires is making no contact or poor contact. Also double check the color coding to verify it is correct. If you see a mistake or problem, cut the end off and start again. A cable tester is invaluable at identifying and highlighting these issues.

When sizing cables remember that an end to end connection should not extend more than 100m (~328ft). Try to minimize the cable length, the longer the cable becomes, the more it may affect performance. This is usually noticeable as a gradual decrease in speed and increase in latency.

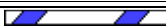
Power over Ethernet (PoE):

Power over Ethernet has been implemented in many variations before IEEE standardized 802.3af. 802.3af specifies the ability to supply an endpoint with 48V DC at up 350mA or 16.8W. The endpoint must be capable of receiving power on either the data pairs [Mode A] (often called phantom power) or the unused pairs [Mode B] in 100Base-TX. PoE can be used with any ethernet configuration, including 10Base-T, 100Base-TX and 1000Base-T. Power is only supplied when a valid PoE endpoint is detected by using a low voltage probe to look for the PoE signature on the endpoint. PoE power is typically supplied in one of two ways, either the host ethernet switch provides the power, or a "midspan" device is plugged in between the switch and endpoints and supplies the power. No special cabling is required.

RJ45 Pin #	Wire Color (T568A)	Wire Diagram (T568A)	10Base-T Signal 100Base-TX Signal	PoE
1	White/Green		Transmit+	Mode A +
2	Green		Transmit-	Mode A +
3	White/Orange		Receive+	Mode A -
4	Blue		Unused	Mode B +
5	White/Blue		Unused	Mode B +
6	Orange		Receive-	Mode A -
7	White/Brown		Unused	Mode B -
8	Brown		Unused	Mode B -

Power over Ethernet Power Delivery

Protocol Details:

	Frequency (MHz)	Symbol Encoding	Signal Rate (Mbaud)	Symbol Rate	Data Encoding	Data Bits per Symbol	Pairs per Channel	Pairs Used	Minimum Cable Category
10BaseT	10	Manchester	10	10	None	1	1	2	3
100BaseT4	12.5	Multi-level, 2T/Hz	25	25	8B6T	8/6	3	4	3
100BaseTX	31.25	MLT-3	125	125	4B5B	4/5	1	2	5
100BaseT2	12.5	PAM5x5 (2D-PAM5)	25	12.5	None	4 (2x2)	2	2	3
1000BaseT	31.25	4D-PAM5	125	31.25	None	8 (4x2)	4	4	5*

*Designed to work on MOST category 5 cable, category 5e specifications ensure 1000Base-T operation

Cable Category Details:

Cable Category	Rated Frequency Bandwidth (MHz)	Common Uses
1	None	Common Use
2	1	Telephone Wiring
3	16	Telephone Wiring, 10Base-T
4	20	Token-Ring, 10Base-T
5	100	100Base-TX, 10Base-T
5e	100	1000Base-T, 100Base-TX
6	250	1000Base-T, 100Base-TX
6a*	500	10GBase-T
7	600	

Increasing category levels are backward compatible.

Manufacturers will often test and certify their cable well beyond the standards.

*10GBase-T should work on Cat6, but to get the full 100m range, Cat 6a is required.

WiFi Global Depot www.wifiglobaldepot.com Your Wireless Partner
 Contact us at (561) 623-WIF5 (623-9435)